

**TECHNICAL DATA**  
**TYPE: DIG-MAZ 500 Vacuum**

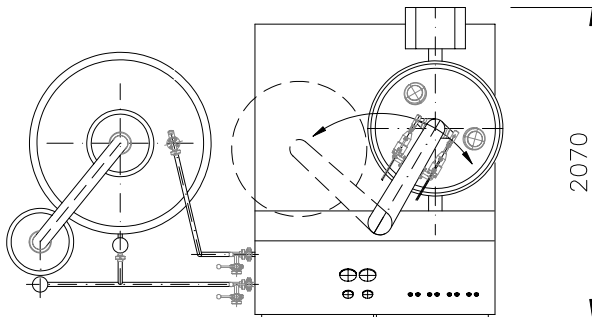
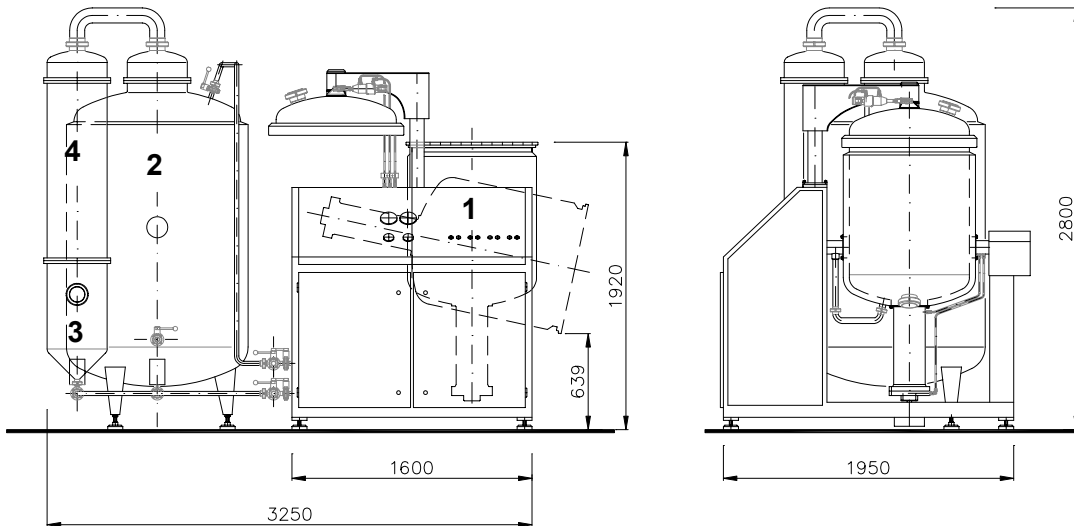

- 1 Digmaz 500**
- 2 Solvent tank**
- 3 Receiver**
- 4 Cooler**

Type:	DIG-MAZ 500	
<b>Extraction tank:</b>	500 liters	Herbs volume
<b>Solvent tank:</b>	1800 liters	
<b>Make-up water:</b>	5 bar	50 l / h
<b>Hot water:</b>	26 m <sup>3</sup> / h / 300 kW	in 90°C / out 80°C
<b>Cooling water:</b>	26 m <sup>3</sup> / h / 300 kW	in 5°C / out 15°C
<b>Distillate:</b>	500 liters / h	
<b>Compressed air:</b>	6 bar	4 m <sup>3</sup> / h
<b>Power supply:</b>	3x400 V / 50 Hz	
<b>Power consumption:</b>	8 kW	
<b>Compressing pressure:</b>	18 t	
<b>Weight:</b>	2.2 t	